

# F2012



FEBER es una marca propiedad de:  
 FEBER is a trademark of:  
 FEBER est une marque déposée appartenant à:  
 Die Marke FEBER ist Eigentum von:  
 Het merk FEBER is eigendom van:  
 A FEBER é uma marca propriedade da:  
 FEBER è una marca proprietà di:  
 FEBER er et registreret varemærke fra:  
 FEBER är ett märke som tillhör:  
 FEBER er et merke som tilhører:  
 FEBER-tuotemerkkin omistaa:  
 Η FEBER είναι μια μάρκα ιδιοκτησίας της Famosa  
 "فیبیر" علامة ملوكة لمجموعة "فاموسا"



Fábricas Agrupadas de Muñecas de Onil, S.A.  
 Edificio FAMOSA  
 Polígono Industrial "Las Atalayas"  
 C/ Del Franco S/N  
 03114 Alicante - España

PESO MÁXIMO RECOMENDADO:  
 RECOMMENDED MAXIMUM WEIGHT:  
 POIDS MAX. RECOMMANDÉ:  
 EMPFOHLENES GEWICHT:  
 MAXIMUM AANBEVOLEN GEWICHT:  
 PESO MÁXIMO RECOMENDADO:  
 PESO MASSIMO RACCOMANDATO:  
 ΜΑΧΙΜΙΟΜ ΑΝΒΕΦΑΛΕΤ ΒΕΓΤ  
 HÖGST REKOMMENDERAD VIKT  
 VEILEDENDE MAKSIMUMSVEKT  
 SUOSITELTU ENIMMÄISPAINO  
 Μέγιστο προτεινόμενο βάρος.  
 25 kg  
 55.12 lb  
 الثقل الأقصى الموصى به



Produced under license of Ferrari SpA.  
 FERRARI, the PRANCING HORSE  
 device, all associated logos and  
 distinctive designs are trademarks of  
 Ferrari SpA. The body designs of the  
 Ferrari cars are protected as Ferrari  
 property under design, trademark and  
 trade dress regulations.



MONTAJE • ASSEMBLY • ASSEMBLAGE • BEDIENUNGSANLEITUNG • MONTAGE • MONTAGEM  
 • MONTAGGIO • MONTERING • KOKOONPANO • ΣΥΝΑΡΜΟΛΟΓΗΣΗ • التركيب



• Realizar por un adulto  
 • This should be done by an adult  
 • A réaliser par un adulte  
 • Dies ist von einem erwachsenen auszuführen  
 • Uit te voeren door een volwassene  
 • A realizar por um adulto  
 • Deve essere fatto da un adulto

• Bør udføres af en voksen person  
 • Att göras av en vuxen  
 • Utføres av en voksen  
 • Kokoaminen jätettävä aikuisen tehtäväksi  
 • Να πραγματοποιείται από έναν ενήλικα.  
 • يقوم بالعمل شخص بالغ

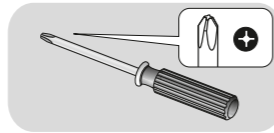

• Herramientas no incluidas.  
 • Tools not included.  
 • Outils non inclus.  
 • Werkzeuge nicht beigegeben.  
 • Gereedschap niet bijgesloten.  
 • Ferramenta não incluída.  
 • Attrezzi non inclusi.

• Værktøj medfølger ikke.  
 • Verktøy medfølger inte.  
 • Verktøyet ikke inkludert.  
 • Ei sisällä työkalua.  
 • Δεν περιλαμβάνονται τα εργαλεία.  
 • لم يتم تضمين أداة

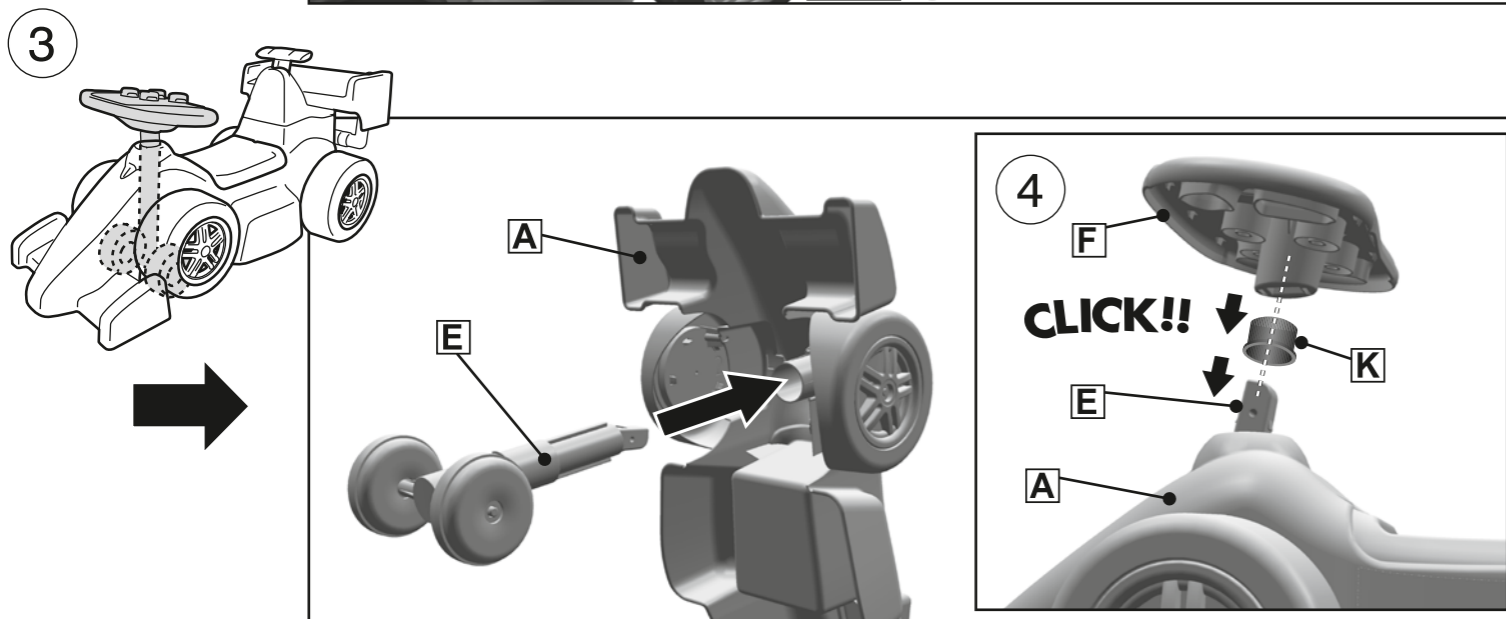
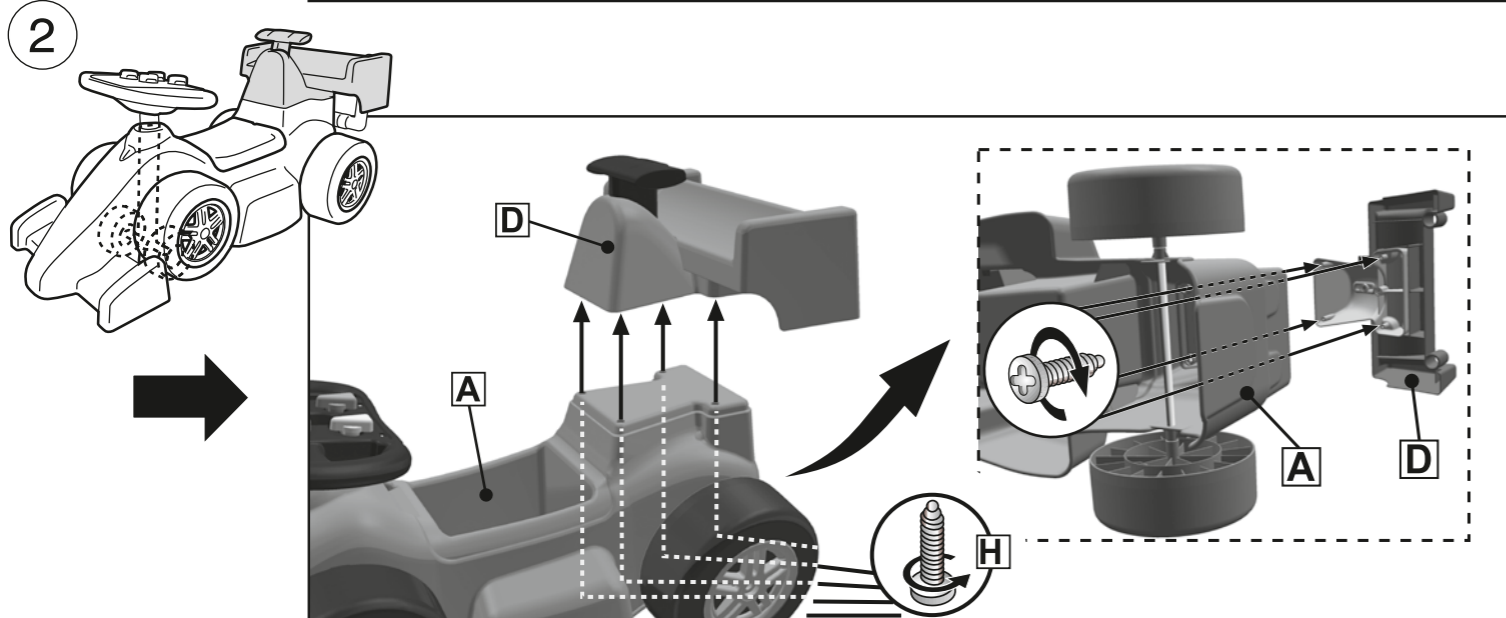
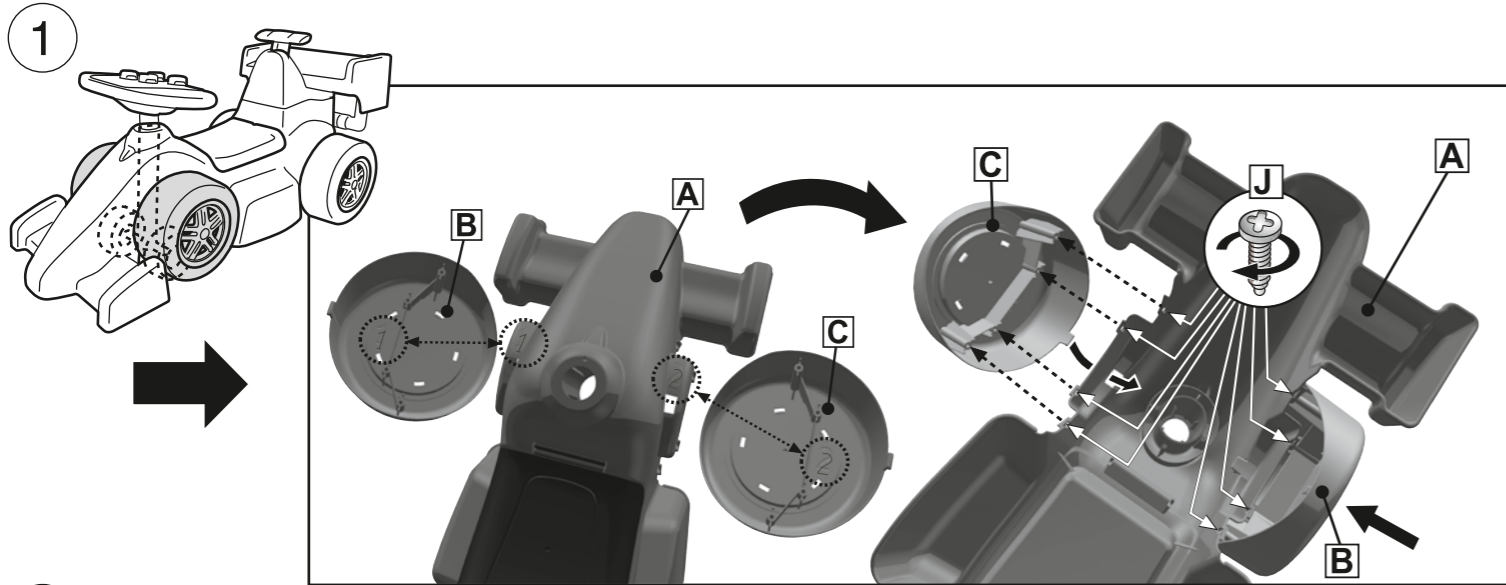

ADHESIVAS • STICKERS • ETIQUETTES AUTOCOLLANTES • SELBSTKLEBENDE STICKER •  
 STICKERS • DECALCOMANIAS • ADESIVI • KLISTERMÆRKER • SJÄLVHÄFTANDE •  
 KLEBEMIDLER • MERKKITARRAT • ΑΥΤΟΚΟΛΛΗΤΑ • لاصق

